

RUBBER EXPANSION JOINT TYPE AS-1

FLAME-PROOF

UNIVERSAL EXPANSION JOINT DN 25 – DN 400

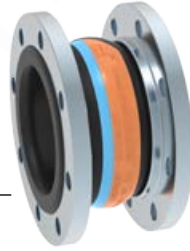

STRUCTURE TYPE AS-1 / RUBBER BELLOWS PN 16

- Universal expansion joint, consisting of a rubber bellows and rotatable flanges
- Highly elastic molded bellows in various rubber grades
- Steel wire cord reinforcement
- Wire-reinforced self-sealing rubber rim
- Electrical impedance < 100 Ohm (DIN IEC 93, VDE 0303-30)

Rubber grade*	EPDM	NBR
Colour code	orange/blue	red/blue
Possible uses	Hot water, acids, lyes	hydrocarbon containing liquids

*Check or inquire about the resistance of the rubber grade to temperature and medium.

Technical design	
Max. perm. operating pressure	16 bar*
Max. perm. temperature	+130 °C
Bursting pressure	≥ 50 bar
Vacuum operation	DN 25 – 50 without vacuum supporting ring, DN 65 – 400 with vacuum supporting ring

Max. operating pressure to be set 30 % lower for shock loads.

*Please consider a decrease of pressure due to temperature (see technical annex).

FLANGES / VERSIONS

- Rotable flanges with stabilizing collar
- Flange drilling for through bolts, DN 25 with Drill holes
- Special machined groove for rubber rim

	Standard	Others
Dimensions	EN 1092	ANSI, BS etc. Connection dimensions see technical annex page 213 – 215
Materials	1.0038 (S235JR)	1.4541, 1.4571 etc.
Corrosion protection	electrogalvanized	hot-dip galvanized, special varnish, special coating, etc.

NOTE

Please comply with the general technical instructions regarding reaction force, moving force, fixed point load, installation instructions etc.

Subject to technical alterations and deviations resulting from the manufacturing process.

Chemicals used for water treatment (particularly in heating systems and coolant systems) can corrode the materials of the rubber expansion joint. According to VDI Directive 2035, DIN 4809 part 1 and VGB R 455P, the manufacturer of the chemicals must state that the materials used in the expansion joint, especially for the rubber bellows, will not be damaged by the chemicals.

APPLICATIONS

- for reducing thermal and mechanical tension in pipes and their system components, e.g.
 - pumps
 - compressors
 - engines
- for muffling vibration and noise
 - at appliances
 - in cooling water and lub oil pipes
- for compensating axial, lateral and angular movement
- to compensate for installation inaccuracies
- to meet fire protection regulations
- shipbuilding industry
- in heating plants

CERTIFICATES

- CE (PED 2014/68/EU)
- American Bureau of Shipping
- DNV GL® / DNV®
- Bureau Veritas
- Lloyd's Register of Shipping
- TÜV/DIN 4809 (DN 25 – 200)
- TÜV Süd (KTA)
- MED
- Others see technical annex

DIMENSIONS STANDARD PROGRAM

DN	BL*	Pressure rate	Ø dj Bellows inner Ø mm	Ø C Raised face outer Ø mm	Ø E Raised face inner Ø mm	Ø W*** Con-volution Ø mm	PN Flange connection EN 1902	Ø D Flange outer Ø mm	b Flange thickness mm
25	125	16	31 ± 3	72	39	78	16**	115	16
32	125	16	31 ± 3	72	39	78	16	140	16
32	150	16	31 ± 3	72	39	88	16	140	16
40	125	16	39 ± 3	81	45	86	16	150	16
40	150	16	39 ± 3	81	45	96	16	150	16
50	125	16	49 ± 3	95	56	97	16	165	16
50	150	16	49 ± 3	95	56	107	16	165	16
65	125	16	65 ± 3	115	72	113	16	185	18
65	150	16	65 ± 3	115	72	123	16	185	18
80	150	16	77 ± 3	127	84	135	16	200	20
100	150	16	100 ± 3	151	109	160	16	220	20
125	150	16	127 ± 3	178	133	184	16	250	22
150	150	16	153 ± 3	206	161	212	16	285	22
175	150	16	176 ± 3	230	185	236	16	315	22
200	150	10	202 ± 3	260	209	265	10	340	25
200	175	10	202 ± 3	260	209	265	10	340	25
250	175	10	252 ± 3	313	262	318	10	395	25
250	200	10	252 ± 3	313	262	318	10	395	25
300	200	10	303 ± 3	363	312	373	10	445	25
350	200	10	344 ± 3	423	360	420	10	505	30
400	200	10	396 ± 3	474	410	460	10	565	30

* DN 25 up to DN 300 also available as type RS-1 in length 130.

** Flanges with drill holes M 12.

*** unpressurized

From DN 200 pressure rate 16 bar also available with flanges PN 16. Please contact us for further flange dimensions.

ACCESSORIES

- Vacuum supporting ring
- Internal guide sleeve
- Protective hood
- Protective tube

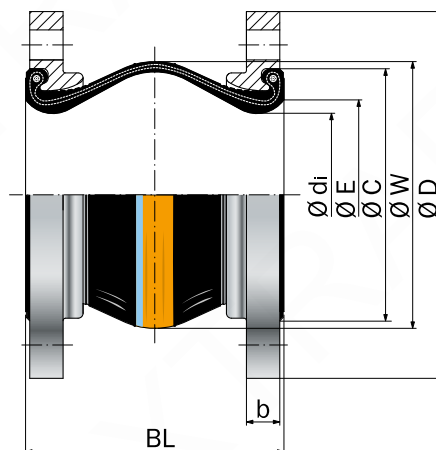

Type AS-1

Universal expansion joint without restraint

MOVEMENT COMPENSATION

DN	BL	Δ ax Axial movement		Δ lat Lateral movement ± mm	Δ ang* Angular movement ± ∠ degrees	A** Effective bellows cross sectional area at 16 bar cm ²	Permissible vacuum w/o supporting ring at length BL bar absolute	Weight approx. kg
		Compression - mm	Elongation + mm					
25	125	30	10	15	25	0	0	2.2
32	125	30	10	15	25	0	0	3.3
32	150	35	15	20	25	-14	0.5	3.4
40	125	30	10	15	25	0	0	3.7
40	150	35	15	20	25	-25	0.7	3.8
50	125	30	10	15	25	0	0	4.4
50	150	35	15	20	25	-14	0.7	4.6
65	125	30	10	15	25	0	0	5.2
65	150	35	15	20	20	-25	0.7	5.4
80	150	40	10	15	20	12	0.2	7.2
100	150	40	10	15	15	9	0.4	8.0
125	150	40	10	15	15	18	0.65	10.7
150	150	40	10	15	12	52	0.65	13.0
175	150	40	10	15	10	54	0.7	15.9
200	150	20	20	10	8	285	0.8	18.8
200	175	45	15	15	8	56	0.7	19.1
250	175	45	15	15	7	191	0.7	24.8
250	200	35	15	15	6	54	0.5	25.1
300	200	45	15	15	6	255	0.75	30.9
350	200	45	15	15	5	563	0.5	42.0
400	200	45	15	15	5	875	0.3	51.0

* Larger Δ ang possible for compressed installation length.

**Effective bellows cross sectional area is a theoretical value.

Please inquire for simultaneous (different) movement.